

Linear Position Sensors

Unsprung Potentiometer – 15mm Square and 9.5mm Diameter Sprung Potentiometer

Unsprung potentiometers should be mounted using only the spherical bearings and not supported anywhere else. The mounting arrangement must ensure that the movement of the sensor is straight and does not bind. The spherical bearings can accommodate a movement of $\pm 12^\circ$. Provision is made to adjust the length of the shaft by 4mm. The shaft, with the bearing attached, is free to rotate. The bearing on the body can be rotated so the relationship between the plane of the bearing and the cable outlet can be adjusted.

Sprung potentiometers are typically used to follow a track on a moving component. The track should be smooth and should not apply side loads to the potentiometer shaft. The potentiometer body should be rigidly fixed. However, in high vibration environments, such as direct mounting on an engine or gearbox, a resilient or anti vibration mounting should be used. Even with such a mounting, sprung potentiometers can be susceptible to bouncing when there is excessive vibration.

The single track sprung potentiometer can be installed with an O ring to seal it to a housing. Note that the potentiometer shaft seal does not resist pressure. The O ring is not available from McLaren Electronic Systems

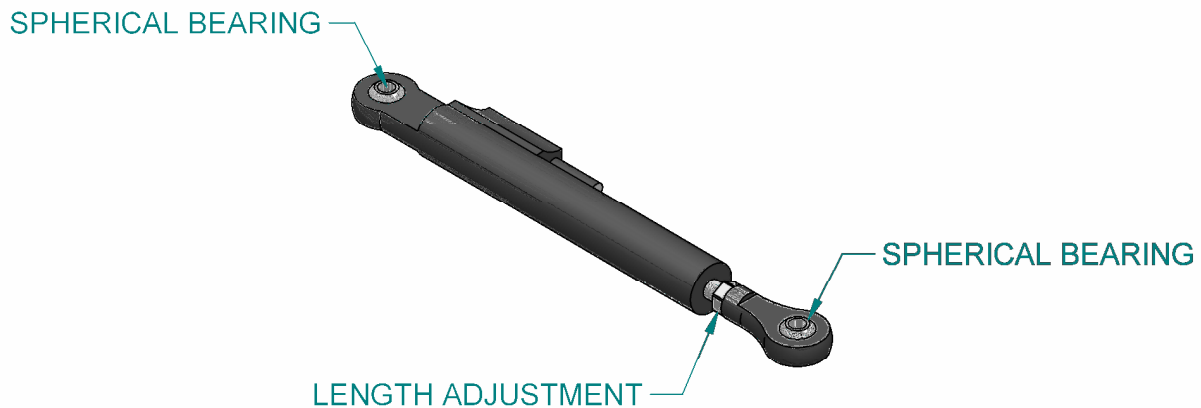

Recommended Installation for Linear Potentiometer

Linear Position Sensors

Linear Hall Effect

The shaft of the sensor can be removed from the housing to assist ease of assembly. The body should be rigidly mounted to a gearbox or engine or similar.

The bodies can be designed with a seal to prevent dirt ingress to the shaft and brushes in dusty environments.

Where possible the shaft should not be free to rotate as this may introduce hysteresis errors.

The sensor should be kept clear of moving ferrous objects or magnetic fields which may interfere with or distort the field produced by the measurement magnet.

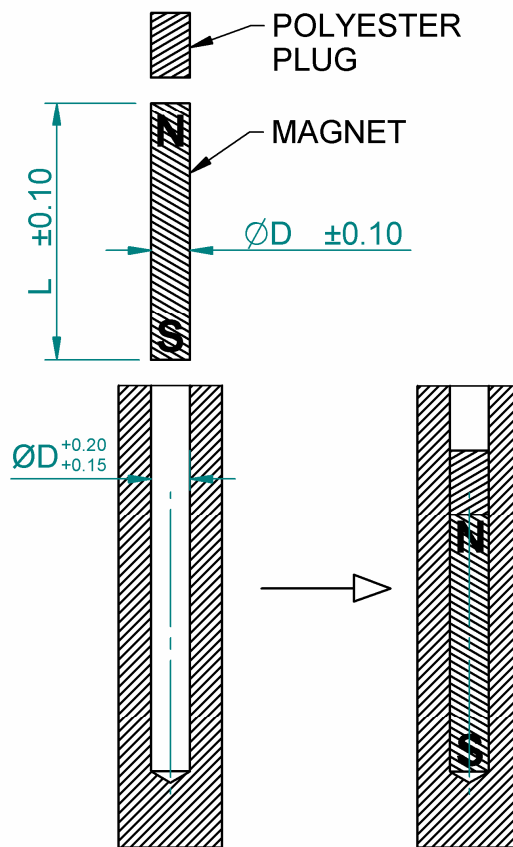

Typical Magnet Installation